

# Godox

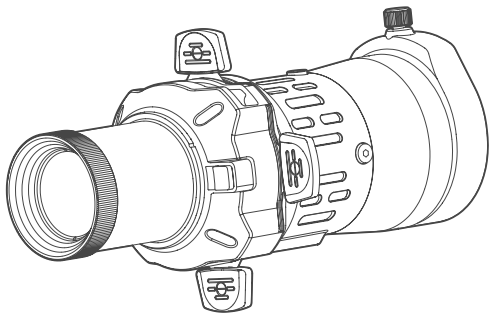

## FP-M FP-R

使用手册

Instruction Manual V1.0

## 前言

感谢您选择神牛 (Godox) 产品!

FP-M / FP-R 采用高品质金属打造,是一款兼具轻巧与坚固的闪光灯投影筒。支持光束切割、光学变焦、图案投影、光束造型等多种创意光效,为摄影作品增添艺术表现力。

- FP-M 适用于方口闪光灯
- FP-R 适用于圆口闪光灯

投影筒类型	套装型号	适用闪光灯机型 / 灯头机型
机顶圆口闪光投影筒 FP-R	FP-R-19 FP-R-36 FP-R-50	AD100Pro、AD200Pro(圆形灯头)、 V1、H200R、V100、V1Pro
机顶方口闪光投影筒 FP-M	FP-M-19 FP-M-36 FP-M-50	EC200、H200、H200II、V860III、V860II、 V850、V850II、V850III、TT685、TT685II、 TT600、TT600S、TT520、TT520II、TT520III、 TT560II、V480、AD200Pro(方形灯头)、 AD200ProII(方形灯头)

## FP-R-19 / FP-M-19 物品清单

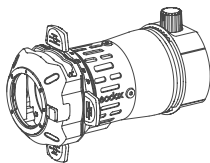

投影筒主体 × 1  
(线图为方口投影筒, 不同  
型号以实物为准)

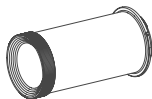

光学投影镜头 19° × 1



支架 AD-E2 × 1

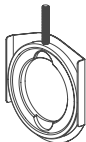

投影片夹 SP-CF × 1

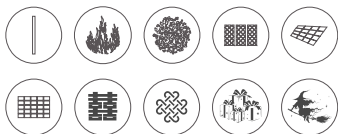

投影片组 MLP-GS × 1



便携包 × 1  
(筒装版不含便携包)



使用手册 × 1

## FP-R-36 / FP-M-36 物品清单

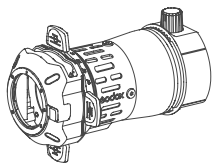

投影筒主体 × 1

(线图为方口投影筒, 不同型号  
以实物为准)



光学投影镜头 36° × 1



支架 AD-E2 × 1

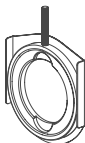

投影片夹 SP-CF × 1

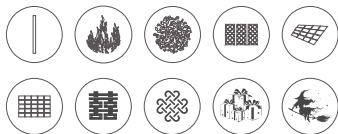

投影片组 MLP-GS × 1



便携包 × 1

(简装版不含便携包)



使用手册 × 1

## FP-R-50 / FP-M-50 物品清单

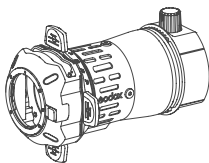

投影筒主体 × 1

(线图为方口投影筒, 不同型号  
以实物为准)

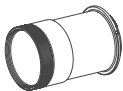

光学投影镜头 50° × 1



支架 AD-E2 × 1

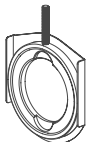

投影片夹 SP-CF × 1

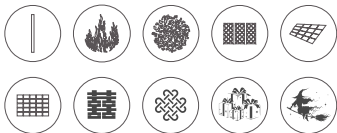

投影片组 MLP-GS × 1



便携包 × 1

(筒装版不含便携包)



使用手册 × 1

**注意:** 本产品光学镜头为 EF 卡口设计。连续全功率使用超过 50 次后, 投影筒表面温度可能过高, 接触皮肤会导致烫伤, 请佩戴隔热手套操作。为避免高温损坏镜头, 请勿使用相机镜头替代。

## 另购附件

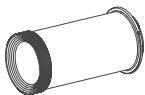

光学投影镜头 SP-19°



光学投影镜头 SP-36°

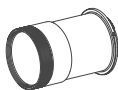

光学投影镜头 SP-50°

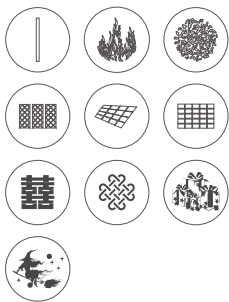

金属投影片套装 MLP-GS



可调光阑 SP-ID

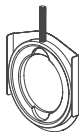

投影片夹 SP-CF

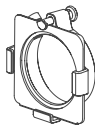

色片夹 SP-CTF



投影扩散片 SP-DUST



色彩效果组 SA-11C



色温调整组 SA-11T

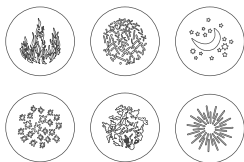

投影片组 (SA-09-001)

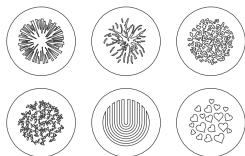

投影片组 (SA-09-002)

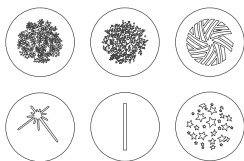

投影片组 (SA-09-003)

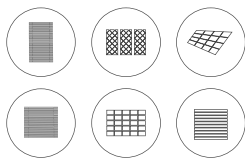

投影片组 (SA-09-004)

## 部件名称

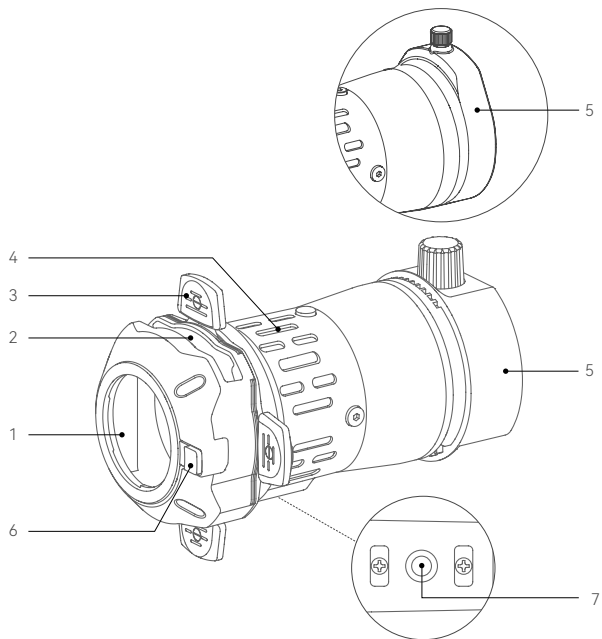

1. 镜头安装口
2. 投影片夹槽 / 光阑槽
3. 切光片
4. 散热孔
5. 圆形卡口转接座 / 方形卡口转接座 (请以实物为准)
6. 拆卸镜头按钮
7. 1/4" 安装螺丝孔

注：切光组件可 360° 旋转。

## 安装镜头

将镜头的红点对准投影筒镜头安装口的红点，然后插入并顺时针旋转直至安装完毕。

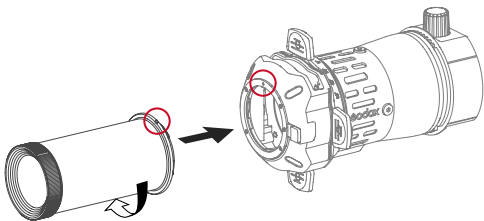

## 拆卸镜头

按住投影筒拆卸按钮的同时，逆时针旋转镜头，然后取下镜头即可完成拆卸。

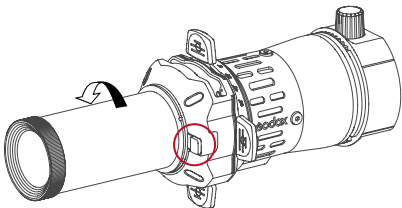

## 安装方形卡口闪光灯 (以 V860III 为例)

将闪光灯方形卡口对准投影筒的转接座插入, 然后顺时针旋转转接座上的旋钮即可安装完毕。

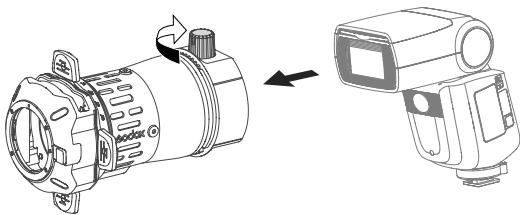

## 拆卸方形卡口闪光灯 (以 V860III 为例)

先逆时针旋转转接座上的旋钮, 然后取下方形卡口闪光灯。

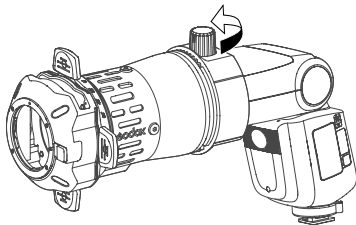

注: 圆形卡口闪光灯装卸原理一致。

## 安装投影片

投影片夹配有锁环，将指尖置于锁环凹槽内逆时针旋转取下，放入金属投影片后，将锁环放回并顺时针旋转锁紧，最后按图示正确方向将投影片夹插入安装槽。

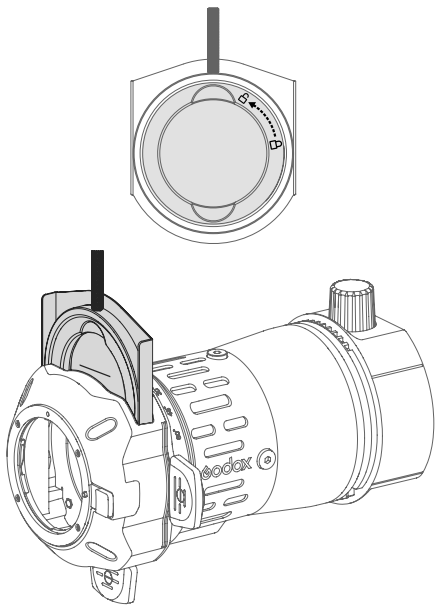

注：投影片夹插入安装槽后不能再插入光阑。

## 规格参数

名称	尺寸	重量
方口闪光灯投影筒 (不含镜头)	134 × 134 × 185.2mm	≈ 685g
圆口闪光灯投影筒 (不含镜头)	134 × 134 × 170mm	≈ 683g
光学投影镜头 19° (收缩)	124 × 65 × 65mm	≈ 450g
光学投影镜头 36° (收缩)	71 × 65 × 65mm	≈ 280g
光学投影镜头 50° (收缩)	93 × 65 × 65mm	≈ 404g

## 闪光指数

测试条件: 闪光灯功率档位为 1/1 档, 测试距离为 1m

投影筒类型	搭配闪光灯 / 灯头	镜头	闪光指数
圆口闪光灯投影筒	AD100Pro	19°	≈ GN45
		36°	≈ GN27
		50°	≈ GN22
方口闪光灯投影筒	V860III	19°	≈ GN42
		36°	≈ GN27
		50°	≈ GN23
	AD200ProII(方形 H200II)	19°	≈ GN55
		36°	≈ GN36
		50°	≈ GN30

数据仅供参考, 规格和参数如有变更, 恕不另行通知。

## Foreword

Thank you for purchasing !

FP-M / FP-R is crafted from high-quality metal, making it a lightweight yet sturdy flash projection tube. It supports beam cutting, optical zoom, pattern projection, beam shaping, and other creative lighting effects, adding artistic expression to photography works.

- **FP-M:** Suitable for rectangular-headed flash units.
- **FP-R:** Suitable for round-headed flash units.

Projectors	Projection Kits	Compatible Flash Models/Flash Heads
Round-head Flash Projector FP-R	FP-R-19 FP-R-36 FP-R-50	AD100Pro, AD200Pro (round flash head), V1, H200R, V100, V1Pro
Square-head Flash Projector FP-M	FP-M-19 FP-M-36 FP-M-50	EC200, H200, H200II, V860III, V860II, V850, V850II, V850III, TT685, TT685II, TT600, TT600S, TT520, TT520II, TT520III, TT560II, V480, AD200Pro (square flash head), AD200ProII (square flash head)

## Name of Parts

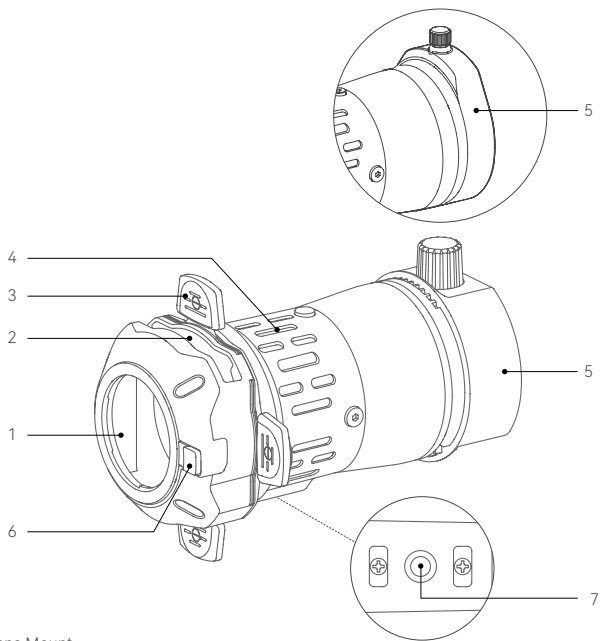

1. Lens Mount

2. Gobo Slot / Iris Diaphragm Slot

3. Shutter Blade

4. Thermovent

5. Round Head Adapter Bracket /  
Square Head Adapter Bracket (the actual product shall prevail)

6. Lens Detach Button

7. 1/4" Screw Mounting Hole

Note: The shutter blade is 360° rotatable.

## What's Inside FP-R-19 / FP-M-19

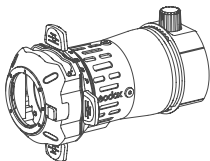

Projector × 1

(The picture shows the square-head projector, please refer to the actual product for use)

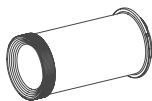

Projection Lens 19° × 1



Bracket AD-E2 × 1

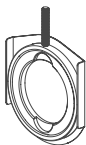

Gobo Holder SP-CF × 1

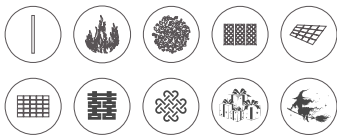

Gobo Set MLP-GS × 1



Carry Bag × 1

(Not included in the Basic Kit)



Instruction Manual × 1

## What's Inside FP-R-36 / FP-M-36

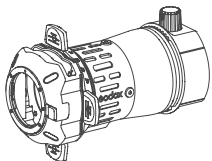

Projector × 1

(The picture shows the square-head projector, please refer to the actual product for use)



Projection Lens 36° × 1



Bracket AD-E2 × 1

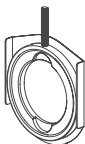

Gobo Holder SP-CF × 1

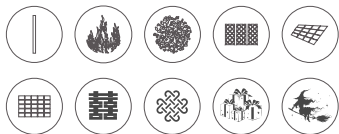

Gobo Set MLP-GS × 1



Carry Bag × 1

(Not included in the Basic Kit)



Instruction Manual × 1

## What's Inside FP-R-50 / FP-M-50

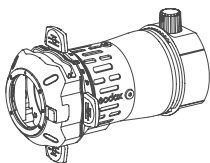

Projector × 1

(The picture shows the square-head projector, please refer to the actual product for use)

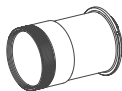

Projection Lens 50° × 1



Bracket AD-E2 × 1

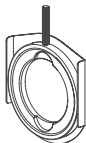

Gobo Holder SP-CF × 1

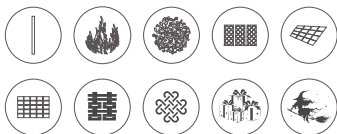

Gobo Set MLP-GS × 1



Carry Bag × 1

(Not included in the Basic Kit)



Instruction Manual × 1

**Important:** The optical lens of this product is an EF mount. After more than 50 consecutive uses at full power, the surface of the projector may be over-heated, and contact with the skin may cause burns, please wear insulated gloves. To prevent high temperature from damaging to your camera lens, please do not use a camera lens as a substitute.

## Separately Sold Accessories

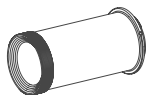

Projection Lens SP-19°



Projection Lens SP-36°

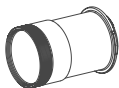

Projection Lens SP-50°

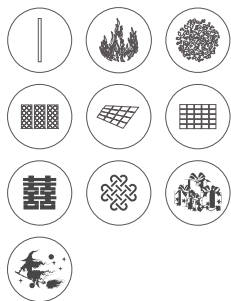

Gobo Set MLP-GS

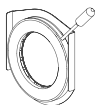

Iris Diaphragm SP-ID

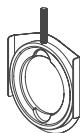

Gobo Holder SP-CF

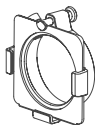

Color Frame SP-CTF



Projection Diffuser SP-DUST



Color Effects Set SA-11C



Color Temperature Adjustment Set SA-11T

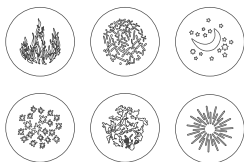

Gobo Set (SA-09-001)

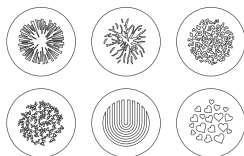

Gobo Set (SA-09-002)

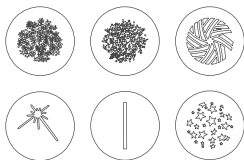

Gobo Set (SA-09-003)

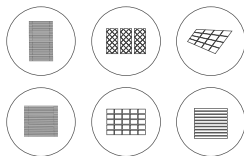

Gobo Set (SA-09-004)

## Install the Lens

Align the red dot on the lens with the red dot on the lens mount and insert in, then rotates the lens clockwise to lock and tighten.

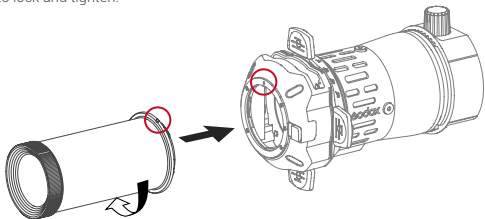

## Disassemble the Lens

Press the lens detach button and rotates the lens anticlockwise to disassemble it.

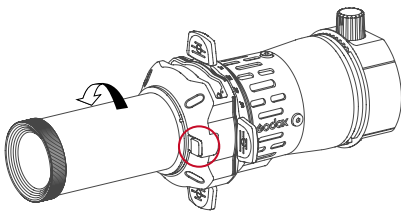

## Install Square Head Mount Flash (take V860III as an example)

Align the square head mount of the flash with the adapter Bracket on the projector and insert in, then rotate the button on the adapter Bracket clockwise to install it.

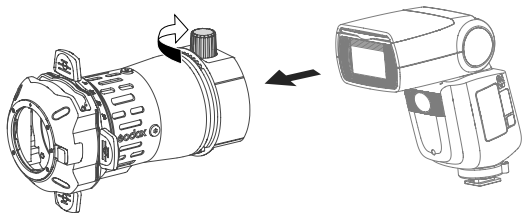

## Disassemble Square Head Mount Flash (take V860III as an example)

Rotate the button on the adapter Bracket anticlockwise, then take down the flash to disassemble it.

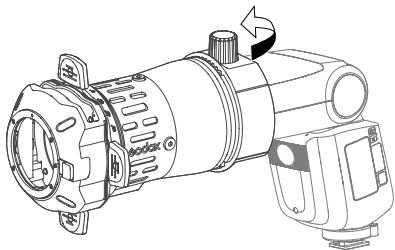

Note: The round head mount flash operates on the same installation and disassembly principle as described above.

## Install the Gobo Holder

The gobo holder is equipped with a locking ring, put your fingertips in the groove of the locking ring and rotate counterclockwise to remove it, mount the gobo set and put the locking ring back then rotate clockwise to tighten it, finally insert the gobo holder into the mounting slot as instructed below.

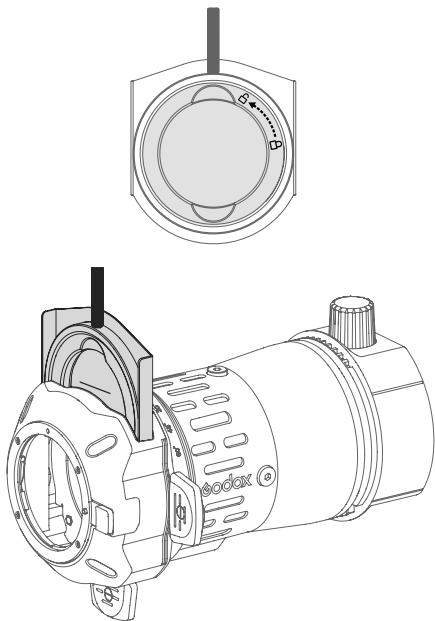

Note: The iris diaphragm is not installable after inserting the gobo holder into the mounting slot.

## Technical Data

Product Name	Dimension	Net Weight
Square-head Flash Projector(without lens)	5.28" × 5.28" × 7.29"	≈ 685g
Round-head Flash Projector(without lens)	5.28" × 5.28" × 6.69"	≈ 683g
Projection Lens 19°(retracted)	4.88" × 2.56" × 2.56"	≈ 450g
Projection Lens 36°(retracted)	2.8" × 2.56" × 2.56"	≈ 280g
Projection Lens 50°(retracted)	3.66" × 2.56" × 2.56"	≈ 404g

## Guide Number

Testing condition: the flash is at 1/1 step and a distance of 1m

Projectors	Flashes/Flash Heads	Lens	Guide Numbers
Round-head Flash Projector	AD100Pro	19°	≈ GN45
		36°	≈ GN27
		50°	≈ GN22
Square-head Flash Projector	V860III	19°	≈ GN42
		36°	≈ GN27
		50°	≈ GN23
	AD200ProII(square flash head H200II)	19°	≈ GN55
		36°	≈ GN36
		50°	≈ GN30

The parameters are for reference only since they vary in different lights. Specifications and data may subject to changes without notice.

## 产品保修

尊敬的用户，本保修卡是申请保修服务的重要凭证，请您配合销售商填写并妥善保管，谢谢！

产品信息	型号	产品条形码
用户信息	姓名	联系电话
	通信地址	
销售商信息	名称	
	联系电话	
	通信地址	
	销售日期	
备注		

注：此表应由销售商盖章确认。

## 产品信息

本文件适用于相关《产品保修信息》（见后面说明）所列产品，其他非属此范围的产品或部件（如促销品、赠品及其他出厂后附加的部件等）不在此保修承诺内。

## 保修期

产品及部件的相应保修期按相关的《产品保修信息》执行。保修期自产品首次购买日起算，购买日以购买产品时保修卡登记日期为准。

## 如何获得保修服务

您可直接与产品销售商或授权服务机构联系，也可拨打神牛产品售后服务电话，与我们联系，由我们的服务人员为您安排服务。申请保修时，您应提供有效的保修卡作为保修凭证，方可获得保修。如您不能提供有效的保修卡，则在我们确认产品或部件属于保修范围的情况下，也可以为您提供保修，但这不作为我们的义务。

## 不适用保修情况

如产品存在下列情况，本文件项下的保证和服务将不适用：①产品或部件超过相应保修期；②错误或不当使用、维护或保管导致的故障或损坏，如：不当搬运；非按产品合理预期用途使用；不当插拔外接设备；跌落或外力挤压；接触或暴露于不当温度、溶剂、酸碱、水浸或潮湿环境；③由非神牛授权机构或人员安装、修理、更改、添加或拆卸造成的故障或损坏；④产品或部件原有识别信息被修改或删除；⑤无有效保修卡；⑥使用非合法授权、非标准或非公开发行的软件造成的故障或损坏；⑦因不可抗力或意外事件造成的故障或损坏；⑧其他非因产品本身质量问题导致的故障或损坏。遇上上述情况，您应向相关责任方寻求解决，神牛对此不承担任何责任。因非在保修期或保修范围内的部件、附件或软件导致产品不能正常使用的，不是保修范围内的故障。产品使用过程中正常的脱色，磨损和消耗，不是保修范围内的故障。

## 产品保修和服务支持信息

产品的保修期和服务类型按以下《产品保修信息》执行：

产品类别	选件名称	保修期(月)	保修服务类型
部件	内部元器件	12	客户送修
其他	如外壳、保护罩、锁紧装置、包装等。	无	无保修

神牛产品售后服务电话 0755-29609320-8062

## Warranty

Dear customers, as this warranty card is an important certificate to apply for our maintenance service, please fill in the following form in coordination with the seller and safe-keep it. Thank you!

<b>Product Information</b>	Model	Product Code Number
<b>Customer Information</b>	Name	Contact Number
	Address	
<b>Seller Information</b>	Name	
	Contact Number	
	Address	
	Date of Sale	
<b>Note</b>		

Note: This form shall be sealed by the seller.

## Applicable Products

The document applies to the products listed on the Product Maintenance Information (see below for further information). Other products or accessories (e.g. promotional items, giveaways and additional accessories attached, etc.) are not included in this warranty scope.

## Warranty Period

The warranty period of products and accessories is implemented according to the relevant Product Maintenance Information. The warranty period is calculated from the day (purchase date) when the product is bought for the first time, and the purchase date is considered as the date registered on the warranty card when buying the product.

## How to Get the Maintenance Service

If maintenance service is needed, you can directly contact the product distributor or authorized service institutions. You can also contact the Godox after-sale service call and we will offer you service. When applying for maintenance service, you should provide valid warranty card. If you cannot provide valid warranty card, we may offer you maintenance service once confirmed that the product or accessory is involved in the maintenance scope, but that shall not be considered as our obligation.

## Inapplicable Cases

The guarantee and service offered by this document are not applicable in the following cases:

① The product or accessory has expired its warranty period; ② Breakage or damage caused by inappropriate usage, maintenance or preservation, such as improper packing, improper usage, improper plugging in/out external equipment, falling off or squeezing by external force, contacting or exposing to the improper temperature, solvent, acid, base, flooding and damp environments, etc; ③ Breakage or damage caused by non-authorized institution or staff in the process of installation, maintenance, alternation, addition and detachment; ④ The original identifying information of product or accessory is modified, alternated, or removed; ⑤ No valid warranty card; ⑥ Breakage or damage caused by using illegally authorized, nonstandard or non-public released software; ⑦ Breakage or damage caused by force majeure or accident; ⑧ Breakage or damage that could not be attributed to the product itself. Once met these situations above, you should seek solutions from the related responsible parties and Godox assumes no responsibility. The damage caused by parts, accessories and software that beyond the warranty period or scope is not included in our maintenance scope. The normal discoloration, abrasion and consumption are not the breakage within the maintenance scope.

## Maintenance and Service Support Information

The warranty period and service types of products are implemented according to the following Product Maintenance Information:

Product Type	Name	Maintenance Period(month)	Warranty Service Type
Parts	Internal electrical parts	12	Customer sends the product to designated site
Other Items	Lamp body, lamp cover, locking device, package, etc.	No	Without warranty

Godox After-sale Service Call **+86-755-29609320(8062)**



Wechat  
Official Account  
神牛微信公众号

制造商：深圳市神牛摄影器材有限公司

地址：深圳市宝安区福海街道塘尾社区耀川工业区厂房2栋

电话：+86-755-29609320 (8062) 传真：+86-755-25723423

邮箱：godox@godox.com 网址：godox.com

MANUFACTURER: GODOX Photo Equipment Co., Ltd.

Add.: Building 2, Yaochuan Industrial Zone, Tangwei Community, Fuhai Street,  
Bao'an District, Shenzhen 518103, China Tel: +86-755-29609320 (8062)

Fax: +86-755-25723423 E-mail: godox@godox.com Website: godox.com

UK  
CA

CE



合格证  
QC PASS

Copyright © 2026 Godox All Rights Reserved.

中国制造 Made in China | 705-FP0000-00