

Godox

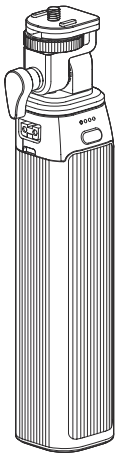

BG02

神牛电池手柄

Godox Battery Grip

使用手册

Instruction Manual

V1.1

重要安全须知与注意事项

Godox 品牌 LED 摄影灯为专业设备，特别是大功率输出的摄影灯，仅限具备资质的技术人员操作。使用前请务必完整阅读并理解产品说明书，严格遵循安全操作指南。未按规定操作可能导致以下风险：人身伤亡、设备损坏或财产损失。



危险

- 禁止使用损坏的产品。产品在使用过程中，因跌落、受到挤压或遭受强烈冲击而造成外壳破裂，请勿继续使用，以免因接触到内部电子元件而受到电击伤害。
- 请勿私自拆卸产品，如产品出现故障，须由本公司或授权的维修人员进行检查维修。如灯珠损坏或因热变形，应停止使用，并及时联系制造商、服务代理商维修灯珠，以免发生意外。
- 请勿在易爆环境中（酒精、汽油等易燃挥发性溶剂或甲烷、乙烷等气体附近）使用和存放本产品。



警告

- 部分产品无防水性能，此类产品请让其保持干燥，禁止浸入水中或其他液体中，安装时需干燥且通风处，避免在雨天、潮湿、多尘或过热环境下使用。请勿将任何物体置于灯具上或使液体流入灯具内部，以免发生意外。
- 不能阻挡、覆盖产品散热口。
- 使用后，产品完全冷切后才能包装。
- 部分产品内置锂电池，此类产品请使用专用的充电器进行充电，并且按正确的操作说明，在规定的电压、温度范围内使用。

小心

- 使用产品前，必须拆除所有运输包装材料和保护装置；
- 不使用产品时，请及时关机和停止供电；
- 存放本产品之前，请确保产品已完全冷却。存放时，将电源线从产品上拔出，产品应放置于产品便携包内或通风干燥处。
- 请勿将产品放置在酒精、汽油等易燃易爆挥发的溶剂附近。
- 安全说明依据本厂严格测试制定，产品设计和规格如有变更，恕不另行通知。客户可以登录神牛官网查看最新的电子版说明，了解产品最新资讯。

前言

感谢您购买神牛产品！

神牛全新推出 BG02，可为小型灯具供电并手持布光，具有大容量锂电池，云台可调，1/4" 螺丝快装灯具，另有螺孔可转接灯架，D-TAP 与 Type-C 双接口等特性可应用于旅拍、创意创作、生活写意等场景。

部件名称

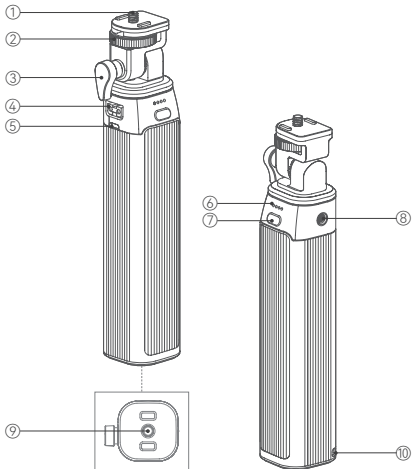

1. 1/4" 螺丝

2. 锁紧装置

3. 方向调节旋钮

4. D-TAP 接口

5. Type-C 接口

6. 电量指示灯

7. 开关按键

8. 1/4" 螺丝孔①

9. 1/4" 螺丝孔②

10. 挂绳孔

物品清单



电池手柄 x1



5/8" 柱销 x1



Type-C 线 x1



D-TAP 线 x1



说明书 x1

温馨提示：说明书中线图均为示意图，仅供参考。由于产品不断更新与升级，产品实物与线图可能存在差异，请以实物为准。

使用方法

搭配摄影灯 ML100R

1. 灯具 1/4" 螺丝孔对准云台上的 1/4" 螺丝，再滚动锁紧装置直到锁紧。

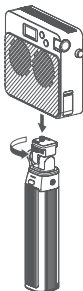

2. 逆时针拧松方向调节旋钮, 可调整需要的云台角度, 调整完成后顺时针拧紧方向调节旋钮。

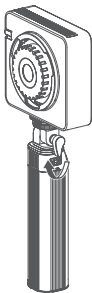

3. 使用标配 Type-C 线接入灯具与电池手柄的 Type-C 接口, 再将灯具开机使用。

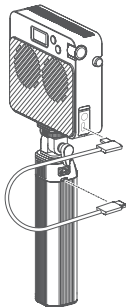

4. 或使用标配 D-TAP 线接入灯具与电池手柄的 D-TAP 接口,再将灯具开机使用。

注: 无需按开关按键, 灯具与电池手柄接线后即开始供电, 电池手柄关机需短按两次开关按键。

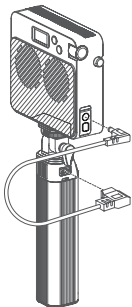

搭配闪光灯 AD200Proll

1. 将灯具安装在云台。

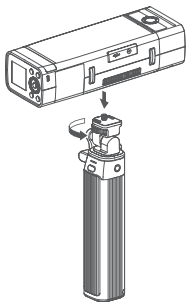

2. 假电池装入灯具后将线接入手柄的 D-TAP 接口, 将灯具开机使用。

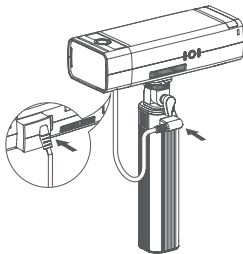

- 注: 1. 云台承受最大力矩为 $1.5N\cdot M$ 。
2. 上述灯具为另购物品。
3. 不使用时请将电源线拔除后再放置。

Type-C 接口充电

Type-C 接口插入标配 Type-C 线, 接入电源后可给电池手柄充电, 低电量时请及时充电后再使用或放置。

通过电量指示灯状态了解充电进度

- 电量低于 25%: 四颗指示灯从左向右依次亮起后全部熄灭, 再以此循环。
 - 电量 25% ~ 50%: 电量指示灯①常亮, 电量指示灯②③④依次亮起后全部熄灭, 再以此循环。
 - 电量 50% ~ 70%: 电量指示灯①②常亮, 电量指示灯③④依次亮起后全部熄灭, 再以此循环。
 - 电量 75% ~ 100%: 电量指示灯①②③常亮, 电量指示灯④闪烁。
- 电量 100%: 四颗指示灯均常亮无闪烁, 已充满电。

开关按键

- 持续按压时间大于 100ms, 小于 2s, 即为短按动作;
- 进入低功耗模式后, 短按会打开电量指示灯, 并进入空载状态, 如检测到有充放电设备则会进入对应充放电状态; 空载状态下, 持续 10s 的 Type-C 接口都未检测到有充电或放电设备接入, 就会进入低功耗状态。
- 在空载状态下, 在 1s 内连续进行 2 次短按操作, 则关机进入低功耗状态, 将关闭电量指示灯和放电输出。

规格参数

型号	BG02
锂电池参数	14.4V 6600mAh 95.04Wh
Type-C 接口	输入: 5V \equiv 3A, 9V \equiv 2A, 12V \equiv 1.5A, 15V \equiv 3A, 20V \equiv 3A
	输出: 5V \equiv 3A, 9V \equiv 3A, 12V \equiv 3A, 15V \equiv 3A, 20V \equiv 5A
D-TAP 接口	输出: 14.4V \equiv 10A
工作环境温度	0°C ~ 45°C
尺寸 \approx	54mm*45mm*238mm
净重 \approx	636g

设计和规格如有变更, 恕不另行通知。

产品保修

尊敬的用户，本保修卡是申请保修服务的重要凭证，请您配合销售商填写并妥善保管，谢谢！

产品信息	型号	产品条码
用户信息	姓名	联系电话
	通信地址	
销售商信息	名称	
	联系电话	
	通信地址	
	销售日期	
备注		

注：此表应由销售商盖章确认。

适用产品

本文件适用于相关《产品保修资讯》（见后面说明）所列产品，其他非属此范围的产品或部件（如促销品、赠品及其他出厂后附加的部件等）不在此保修承诺内。

保修期

产品及部件的相应保修期按相关的产品保修信息执行。保修期自产品首次购买日起算，购买日以购买产品时保修卡登记日期为准。

如何获得保修服务

您可直接与产品销售商或授权服务机构联系，也可拨打神牛产品售后服务电话，与我们联系，由我们的服务人员为您安排服务。申请保修时，您应提供有效的

保修卡作为保修凭证，方可获得保修。如您不能提供有效的保修卡，则在我们确认产品或部件属于保修范围的情况下，也可以为您提供保修，但这不作为我们的义务。

不适用保修情况

如产品存在下列情况，本文件项下的保证和服务将不适用：①产品或部件超过相应保修期；②错误或不当使用、维护或保管导致的故障或损坏，如：不当搬运；非按产品合理预期用途使用；不当插拔外接设备；跌落或外力挤压；接触或暴露于不适当温度、溶剂、酸碱、水浸或潮湿环境；③由非神牛授权机构或人员安装、修理、更改、添加或拆卸造成的故障或损坏；④产品或部件原有识别信息被修改变更或删除；⑤无有效保修卡；⑥使用非合法授权、非标准或非公开发行的软件造成的故障或损坏；⑦因不可抗力或意外事件造成的故障或损坏；⑧其他非因产品本身质量问题导致的故障或损坏。遇上述情况，您应向相关责任方寻求解决，神牛对此不承担任何责任。因非在保修期或保修范围内的部件、附件或软件导致产品不能正常使用的，不是保修范围内的故障。产品使用过程中正常的脱色，磨损和消耗，不是保修范围内的故障。

产品保修和服务支持信息

产品的保修期和服务类型按以下《产品保修信息》执行：

类别	名称	保修期(月)	保修服务类型
带电性能的 部件	电路板	12	客户送修
其他	线材或其他包装	无	无保修

神牛产品售后服务电话：0755-29609320-8062

Important Safety Instructions and Precautions

Godox LED lights, especially those with high power output, are professional equipment and should only be operated by professionals. Carefully read and fully understand the instruction manual before use and strictly follow the safety instructions. Failure to do so may result in death, serious injury, damage to the product, or other property damage.



Danger

- Do not use damaged product. Stop using immediately if the product shell is cracked due to falling, squeezing, or strong impact, to avoid touching the internal electronic components and getting an electric shock.
- Do not disassemble the product without permission. If the product malfunctions, it must be checked and repaired by authorized maintenance personnel. If the lamp bead is damaged or deformed by heat, stop using it, and contact the manufacturer, service agent or qualified maintenance personnel to replace the lamp bead in time to avoid accidents.
- Do not use and store this product in explosive atmospheres (near flammable volatile solvents such as alcohol, gasoline, or gases such as methane and ethane).



Warning

- This equipment is not waterproof, please keep it dry and do not immerse it in water or other liquids. The equipment should be installed in a dry and ventilated place, and avoid using it in rainy, humid, dusty or overheated environments. Do not place any objects on the light or let liquid flow into the light to avoid accidents.
- Do not block or cover the heat dissipation port of the product.

- After use, the product should be completely cooled before packaging.
- Some products have built-in lithium batteries. Please use a dedicated charger to charge, and use them within the specified voltage and temperature range according to the correct operating instructions.

Attention

- All transport protective materials and packages on the product must be removed before use.
- When not in use, please turn off the product and stop the power supply promptly.
- Before storing, make sure that the equipment has cooled down completely. For storage, unplug the power cord from the equipment. The equipment should be placed in the carrying case or in a ventilated dry place.
- Do not place equipment near flammable and volatile solvents such as alcohol and gasoline.
- The safety instructions are formulated according to the strict testing of the factory, and the design and specifications of the equipment are subject to change without prior notice. Customers can view the latest electronic instruction manuals on the official website of Godox and learn about the latest product information.

Foreword

Thank you for purchasing !

Godox battery grip BG02 is designed to supply power and handheld support for small fixtures. With the characteristics of large-capacity lithium battery, flexibly adjustable mount, 1/4" screw port with adapter screw for light stand, D-TAP and USB-C dual-port, it's applicable to travel photography, creative creation, life writing and other scenes.

Names of Parts

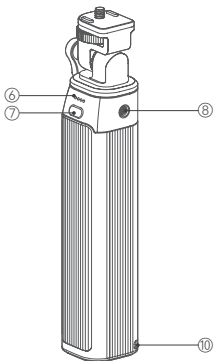
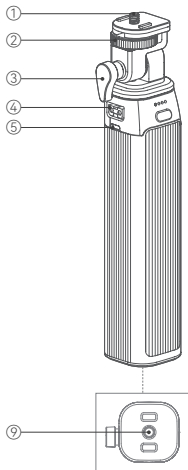

1. 1/4" Screw
2. Locking Device
3. Direction Adjusting Knob
4. D-TAP Port
5. USB-C Port

6. Battery Level Indicator
7. Power Switch Button
8. 1/4" Screw Port ①
9. 1/4" Screw Port ②
10. Lanyard Hole

What's Inside



Battery Grip x1



5/8" Screw Pin x1



USB-C Cable x1



D-TAP Cable x1



Instruction Manual x1

Note: Due to continuous updates and upgrades of the products, there may be differences between the actual products and the pictures. Therefore, the pictures are for reference only, products to prevail in kind.

Using Instructions

With LED Light ML100R

1. Align the 1/4" screw port on the fixture with the 1/4" screw on the mount of battery grip, then rotate the locking device until it is tightened.

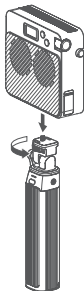

2. Loosen the direction adjusting knob by rotating counterclockwise, adjust the mount to the desired angle, and then tighten the direction adjusting knob by rotating clockwise.

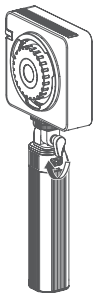

3. Connect the fixture to the USB-C port on the battery grip with the attached USB-C cable, then power on the fixture.

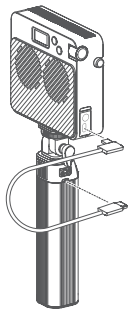

4. Connect the fixture to the D-TAP port on the battery grip with the attached D-TAP cable, then power on the fixture.

Note: No need to press the power switch button, the battery grip will start to supply power when it is connected to the fixture, and the battery grip will be turned off by pressing the power switch button twice.

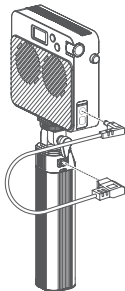

With Flash AD200Proll

1. Install the fixture onto the mount.

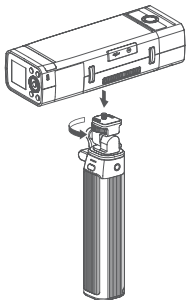

2. Install the dummy battery onto the fixture then insert the cable into D-TAP port on the grip, then power on the fixture.

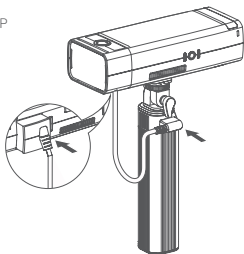

Note: 1. The max torque to which the mount subjected is 1.5N*M.
2. The above fixture is sold separately.
3. When not in use, please unplug the power cord before placing it.

Charging Through USB-C Port

Insert the attached USB-C cable into the USB-C port on the battery grip, then connect to the power supply to charge it. When the battery level is low, please charge it in time before using or placing it.

Check the Charging Status by Battery Level Indicators

- Battery level below 25%: Four indicators turn on sequentially from left to right and then all turn off, and then cycle again.
- Battery level 25% ~ 50%: Battery indicator ① is constant on, battery indicators ②③④ turn on sequentially and then all turn off, and then cycle again.
Battery level 50% ~ 70%: Battery indicators ①② are constant on, battery indicators ③④ turn on sequentially and then both turn off, and then cycle again.
- Battery level 75% ~ 100%: Battery indicators ①②③ are constant on, battery indicator ④ is flashing.

- Battery level 100%: All four indicators are constant on without flashing, fully charged.

Power Switch Button

- Continuous pressing time more than 100ms but less than 2s is called short press action.
- In the low-power mode, short press will turn on the battery level indicator and enter the no-load state. If a charging or discharging device is detected, it will enter the corresponding charging or discharging state. In the no-load state, if no charging or discharging device access is detected in the USB-C port for a sustained period of 10s, then it will enter the low-power state.
- Two consecutive short presses within 1s in no-load state will turn off the device and enter the low-power state, and the battery level indicators and discharge output will also be turned off.

Technical Data

Model	BG02
Lithium Battery Parameters	14.4V 6600mAh 95.04Wh
USB-C Port	Input: 5V≡3A, 9V≡2A, 12V≡1.5A, 15V≡3A, 20V≡3A
	Output: 5V≡3A, 9V≡3A, 12V≡3A, 15V≡3A, 20V≡5A
D-TAP Port	Output: 14.4V≡10A
Working Environment Temperature	0°C ~ 45°C
Dimension ≈	2.13"*1.77"*9.37"
Net Weight ≈	636g

Specifications and data may subject to changes without notice.

FCC Caution

This device complies with part 15 of the FCC Rules. Operation is subject to the following two conditions:

- (1) This device may not cause harmful interference, and
- (2) this device must accept any interference received, including interference that may cause undesired operation.

Any Changes or modifications not expressly approved by the party responsible for compliance could void the user's authority to operate the equipment.

IC Warning

This device complies with Industry Canada licence-exempt RSS standard(s). Operation is subject to the following two conditions:

- (1) This device may not cause interference, and
- (2) This device must accept any interference, including interference that may cause undesired operation of the device.

Le présent appareil est conforme aux CNR d'Industrie Canada applicables aux appareils radio exempts de licence. L'exploitation est autorisée aux deux conditions suivantes:

- (1) l'appareil ne doit pas produire de brouillage, et
- (2) l'utilisateur de l'appareil doit accepter tout brouillage radioélectrique subi, même si le brouillage est susceptible d'en compromettre le fonctionnement

Declaration of Conformity

GODOX Photo Equipment Co.,Ltd. hereby declares that this equipment are in compliance with the essential requirements and other relevant provisions of Directive 2014/35/EU,2014/30 EU. They are allowed to be used in all EU member states. For more information of DoC, Please click this web link:<https://www.godox.com/eu-declaration-of-conformity/>

Warranty

Dear customers, as this warranty card is an important certificate to apply for our maintenance service, please fill in the following form in coordination with the seller and safe-keep it. Thank you!

Product	Model	Product Code Number
Information	Name	Contact Number
Customer	Address	
Information	Name	
	Contact Number	
Seller	Address	
Information	Date of Sale	
Note:		

Note: This form shall be sealed by the seller.

Applicable Products

The document applies to the products listed on the Product Maintenance Information (see below for further information). Other products or accessories (e.g. promotional items, giveaways and additional accessories attached, etc.) are not included in this warranty scope.

Warranty Period

The warranty period of products and accessories is implemented according to the relevant Product Maintenance Information. The warranty period is calculated from the day(purchase date) when the product is bought for the first time, And the purchase date is considered as the date registered on the warranty card when buying the product.

How to Get the Maintenance Service

If maintenance service is needed, you can directly contact the product distributor or authorized service institutions. You can also contact the Godox after-sale service call and we will offer you service. When applying for maintenance service, you should provide valid warranty card. If you cannot provide valid warranty card, we may offer you maintenance service once confirmed that the product or accessory is involved in the maintenance scope, but that shall not be considered as our obligation.

Inapplicable Cases

The guarantee and service offered by this document are not applicable in the following cases: ① . **The product or accessory has expired its warranty period;** ② . **Breakage or damage caused by inappropriate usage, maintenance or preservation, such as improper packing, improper usage, improper plugging in/out external equipment, falling off or squeezing by external force, contacting or exposing to the improper temperature, solvent, acid, base, flooding and damp environments, etc;** ③ . **Breakage or damage caused by non-authorized institution or staff in the process of installation, maintenance, alternation, addition and detachment;** ④ . **The original identifying information of product or accessory is modified, alternated, or removed;** ⑤ . **No valid warranty card;** ⑥ . **Breakage or damage caused by using illegally authorized, nonstandard or non-public released software;** ⑦ . **Breakage or damage caused by force majeure or accident;** ⑧ . **Breakage or damage that could not be attributed to the product itself.** Once met these situations above, you should seek solutions from the related responsible parties and Godox assumes no responsibility. The damage caused by parts, accessories and software that beyond the warranty period or scope is not included in our maintenance scope. The normal discoloration, abrasion and consumption are not the breakage within the maintenance scope.

Maintenance and Service Support Information

The warranty period and service types of products are implemented according to the following Product Maintenance Information:

Product Type	Name	Maintenance Period(month)	Warranty Service Type
Parts with electrical properties	Circuit board	12	Customer sends the product to designated site
Other Items	Cable, or other packages, etc.	NO	Without warranty

Godox After-sale Service Call 0755-29609320-8062



Wechat
Official Account
神牛微信公众号

深圳市神牛摄影器材有限公司

地址：深圳市宝安区福海街道塘尾社区耀川工业区厂房2栋

电话：0755-29609320(8062) 传真：0755-25723423 邮箱：godox@godox.com

GODOX Photo Equipment Co., Ltd.

Add.: Building 2, Yaochuan Industrial Zone, Tangwei Community, Fuhai Street, Bao'an District, Shenzhen 518103, China

Tel: +86-755-29609320(8062) Fax: +86-755-25723423

E-mail: godox@godox.com

www.godox.com

Made in China | 705-BG0200-02

